

Revisions 2018

Section 1.2: Changed the PN MDL

Section 1.3: Added quantitation limits for sediment samples and changed the quantitation limit for PN.

Section 3.10.2: Added K-factor spread for nitrogen.

Section 11.2.2: Changed sample tray set-up in Table 4 to reflect current operating procedures.

Updated Table 5 to include a newer version of the PC/PN preparation bench sheet.

1. SCOPE and APPLICATION

- 1.1. Elemental analysis is used to determine particulate carbon (PC), and particulate nitrogen (PN) in fresh, estuarine and coastal waters and sediments as well as for plant and animal tissue and soils. The method measures the PC and PN irrespective of source (organic or inorganic.)
- 1.2. A Method Detection Limit (MDL) of 0.0633 mg C/l and 0.0263 mg N/l, for filtered samples, and 0.130 %C and 0.008% N for sediment samples, were determined using the Student's *t* value (3.143) times the standard deviation of seven replicates. If more than seven replicates are used to determine the MDL, refer to the Student's *t* test table for the appropriate n-1 value.
- 1.3. The quantitation limit was set at 0.1899 mg C /L and 0.0789 mg N/l for filtered samples, and 0.39 %C and 0.024% N for sediment samples. These values are three times the method detection limit set for each parameter.
- 1.4. This procedure should be used by analysts experienced in the theory and application of elemental analysis. A minimum of 3 months experience with an elemental analyzer is recommended.
- 1.5. This method is for use by all programs that require analysis of particulate carbon and nitrogen in water and sediment, soils and tissues. The need to determine the organic fraction of the total particulate carbon and nitrogen in samples depends on the data-quality objectives of the study. Section 11.2.5 outlines the procedure used to ascertain the organic fraction.

2. SUMMARY

- 2.1. In the Exeter Analytical, Inc. Model CE-440 Elemental Analyzer, the carbon and nitrogen content in organic and inorganic compounds can be determined. Combustion of the sample occurs in pure oxygen under static conditions. The combustion train and analytical system are shown below in the CE-440 flow diagram. Helium is used to carry the combustion products through the analytical system to atmosphere, as well as for purging the instrument. Helium was selected for this purpose because it is chemically inert relative to tube packing chemicals, and it has a very high coefficient of thermal conductivity. The products of combustion are passed over suitable reagents in the combustion tube to assure complete oxidation and removal of undesirable by-products such as sulfur, phosphorus and halogen gases. In the reduction tube, oxides of nitrogen are converted to molecular nitrogen and residual oxygen is removed. In the mixing volume the sample gasses are thoroughly homogenized at precise volume, temperature, and pressure. This mixture is released through the sample volume into the thermal conductivity detector. Between the first of three pairs of thermal conductivity cells an absorption trap removes water from the sample gas. The differential signal read before and after the trap reflects the water concentration and, therefore, the amount of hydrogen in the original sample. A similar measurement is made of the signal output of a second pair of thermal conductivity cells, between which a trap removes carbon dioxide, thus determining the carbon content. The remaining gas now consists only of helium and nitrogen. This gas

passes through a thermal conductivity cell and the output signal is compared to a reference cell through which pure helium flows. This gives the nitrogen concentration.

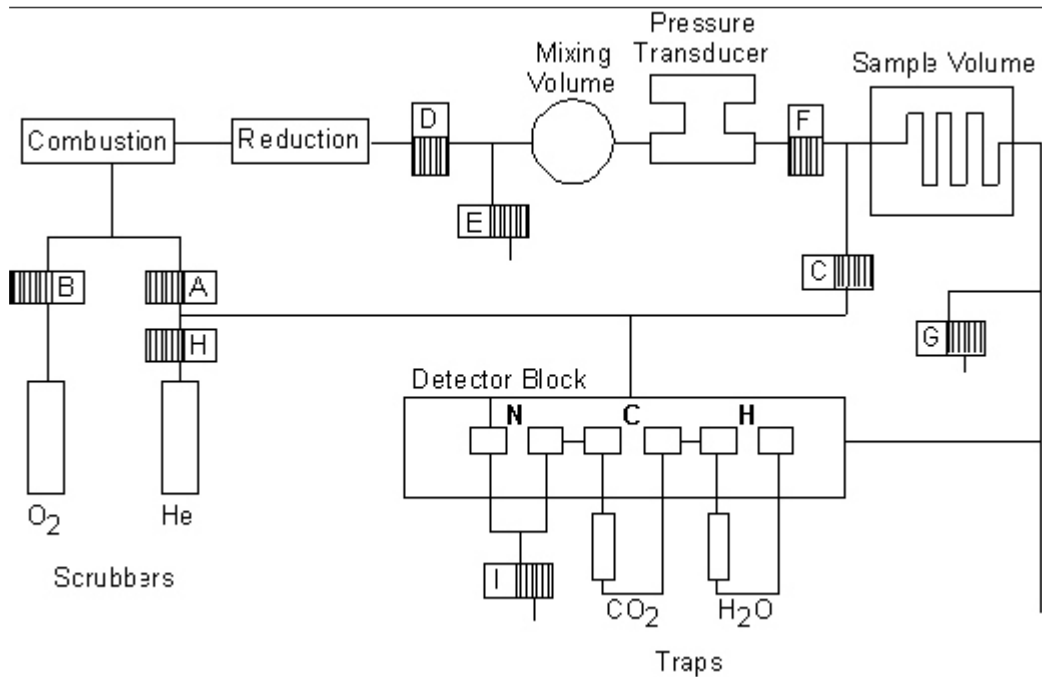

FIGURE 1. Schematic diagram of the Exeter Analytical, Inc. CE-440 Elemental Analyzer

3. DEFINITIONS

- 3.1. **Acceptance Criteria** - Specified limits placed on characteristics of an item, process, or service defined in a requirement document. (ASQC)
- 3.2. **Accuracy** - The degree of agreement between an observed value and an accepted reference value. Accuracy includes a combination of random error (precision) and systematic error (bias) components which are due to sampling and analytical operations; a data quality indicator. (QAMS)
- 3.3. **Aliquot** - A discrete, measured, representative portion of a sample taken for analysis. (EPA QAD Glossary)
- 3.4. **Batch** - Environmental samples, which are prepared and/or analyzed together as a group using the same calibration curve or factor with the same process and personnel using the same lot(s) of reagents. An analytical batch is composed of approximately 50 environmental samples meeting the above mentioned criteria and with a maximum time between the start of processing of the first and last sample in the batch to be 6-10 hours. An analytical batch defined by NELAC can

- include samples originating from various environmental matrices and can exceed 20 samples. (NELAC/EPA)
- 3.5. **Blank** - A sample that has not been exposed to the analyzed sample stream in order to monitor contamination during sampling, transport, storage or analysis. The blank is subjected to the usual analytical and measurement process to establish a zero baseline or background value and is sometimes used to adjust or correct routine analytical results. (ASQC)
 - 3.5.1. **Blank value** = blank read minus blank zero. An indicator of the stability of the system. (Exeter)
 - 3.6. **Bridge** - Electrical configuration of the thermal conductivity filaments.(Exeter)
 - 3.7. **Calibrate** - To determine, by measurement or comparison with a standard, the correct value of each scale reading on a meter or other device, or the correct value for each setting of a control knob. The levels of the applied calibration standard should bracket the range of planned or expected sample measurements. (NELAC)
 - 3.8. **Calibration** - The set of operations which establish, under specified conditions, the relationship between values indicated by a measuring device. The levels of the applied calibration standard should bracket the range of planned or expected sample measurements. (NELAC)
 - 3.9. **Calibration Method** - A defined technical procedure for performing a calibration. (NELAC)
 - 3.10. **Calibration Standard** - A substance or reference material used to calibrate an instrument. (QAMS)
 - 3.10.1. **Initial Calibration Standard (CAL)** - An accurately weighed amount of a certified chemical used to calibrate the instrument response with respect to analyte mass. For this procedure the calibration standard is acetanilide, 99.9%+ purity. It has known percentages of C, H, and N.
 - 3.10.2. **Initial Calibration Verification (ICV)** - An individual standard, analyzed initially, prior to any sample analysis, which verifies acceptability of the calibration curve or previously established calibration curve. To verify that the instrument is running well, all the individual K-Factor values should be within +/- 0.08 of the mean for carbon and +/- 0.22 of the mean for nitrogen. This may be a substitute for the ICV.
 - 3.10.3. **Continuing Calibration Verification (CCV)** - An individual standard which is analyzed after 25 samples and at the end of the analysis run cycle. This standard may be a certified reference material or internal standard such as Atropine.
 - 3.11. **Capsule** - Aluminum container. Used for containing samples and standards with an accurate weight and maintains integrity prior to combustion.
 - 3.12. **Certified Reference Material** - A reference material one or more of whose property values are certified by a technically valid procedure, accompanied by or traceable to a certificate or other documentation which is issued by a certifying body. (ISO 17025)
 - 3.13. **Combustion Time** - Time for sample to fully combust in an oxygen environment.
 - 3.14. **Combustion Tube** - Quartz tube packed with reagents and used for sample combustion.

- 3.15. **Conditioner** - A standard chemical which is not necessarily accurately weighed that is used to coat the surfaces of the instrument with the analytes (water vapor, carbon dioxide, and nitrogen).
- 3.16. **Corrective Action** - Action taken to eliminate the causes of an existing nonconformity, defect or other undesirable situation in order to prevent recurrence. (ISO 8402)
- 3.17. **Deficiency** - An unauthorized deviation from acceptable procedures or practices. (ASQC)
- 3.18. **Demonstration of Capability** - A procedure to establish the ability of the analyst to generate acceptable accuracy. (NELAC)
- 3.19. **Detection Limit** - The lowest concentration or amount of the target analyte that can be determined to be different from zero by a single measurement at a stated degree of confidence.
- 3.20. **Detector** - Consists of three bridges and determines the percentages of carbon, hydrogen, and nitrogen in the sample via thermal conductivity.
- 3.21. **Detector Oven** - Keeps the temperature of the detector, pressure transducer, mixing volume, and sample volume constant.
- 3.22. **Double Drop** - Two samples are dropped for one run - used for filter and inorganic applications. Sample requires a + prefix.
- 3.23. **External Standard (ES)** - A pure analyte (atropine) that is measured in an experiment separate from the experiment used to measure the analyte(s) in the sample. The signal observed for a known quantity of the pure external standard is used to calibrate the instrument response for the corresponding analyte(s). The instrument response is used to calculate the concentrations of the analyte(s) in the unknown sample.
- 3.24. **Field Duplicates (FD1 and FD2)** - Two separate samples collected at the same time and place under identical circumstances and treated exactly the same throughout field and laboratory procedures. Analyses of FD1 and FD2 give a measure of the precision associated with sample collection, preservation and storage, as well as with laboratory procedures.
- 3.25. **Fill Time** - Time required to build-up the pressure in the mixing volume to 1500 mm Hg.
- 3.26. **Filtered Sample** - An accurately measured amount of water from fresh, estuarine or coastal samples, concentrated on a filter pad by filtering through a 25 mm Whatman GF/F filter or equivalent, which has been pre-combusted at 500° C for 90 minutes.
- 3.27. **Furnace** - Heats the reduction and combustion tubes to operating temperature.
- 3.28. **Heated Line** - Connects the reduction tube outlet to the inlet of the mixing volume. Heated to prevent condensation of gases on tube walls.
- 3.29. **Holding Time** - The maximum time which samples may be held prior to analysis and still be considered valid. (40 CFR Part 136) The time elapsed from the time of sampling to the time of extraction or analysis, as appropriate.
- 3.30. **Inject Solenoid** - Solenoid used on the automated injection system to actuate the rotation of the sample wheel.
- 3.31. **Injection** - Moving the ladle containing a sleeve with the sample into the combustion furnace.

- 3.32. **Injector Box** - The box assembly that houses the sample wheel.
- 3.33. **Instrument Detection Limit (IDL)** - The minimum quantity of analyte or the concentration equivalent which gives an analyte signal equal to three times the standard deviation of the background signal at the selected wavelength, mass, retention time, absorbance line, etc.
- 3.34. **K-Factor** - Instrument sensitivity factor in microvolts per microgram, calibrated using a calibration standard.
- 3.35. **Laboratory Duplicates (LD1 and LD2)** - Two aliquots of the same sample taken in the laboratory and analyzed separately with identical procedures. Analyses of LD1 and LD2 indicate precision associated with laboratory procedures, but not with sample collection, preservation, or storage procedures.
- 3.36. **Laboratory Reagent Blank (LRB)** - A matrix blank (i.e., a pre-combusted filter or sediment capsule) that is treated exactly as a sample including exposure to all glassware, equipment, solvents, and reagents that are used with other samples. The LRB is used to determine if method analytes or other interferences are present in the laboratory environment, the reagents, or the apparatus.
- 3.37. **Laboratory Control Sample (LCS)** - A sample matrix, free from the analytes of interest, with verified known amounts of analytes from a source independent of the calibration standards or a material containing known and verified amounts of analytes. The LCS is generally used to establish intra-laboratory or analyst-specific precision and bias or to assess the performance of all or a portion of the measurement system. (NELAC)
- 3.38. **Ladle** - Transports the capsule with the sample into a combustion furnace
- 3.39. **Limit of Detection (LOD)** - The lowest concentration level that can be determined by a single analysis and with a defined level of confidence to be statistically different from a blank. This is also referred to as the MDL. (ACS)
- 3.40. **Limit of Quantitation (LOQ)** - The minimum levels, concentrations, or quantities of a target variable (target analyte) that can be reported with a specified degree of confidence. The LOQ is set at 3 to 10 times the LOD, depending on the degree of confidence desired. This is also referred to as the Quantitation Limit.
- 3.41. **Linear Dynamic Range (LDR)** - The absolute quantity over which the instrument response to an analyte is linear. This specification is also referred to as the Linear Calibration Range (LCR).
- 3.42. **Material Safety Data Sheet (MSDS)** - Written information provided by vendors concerning a chemical's toxicity, health hazards, physical properties, fire, and reactivity data including storage, spill, and handling precautions.
- 3.43. **May** - Denotes permitted action, but not required action. (NELAC)
- 3.44. **Method Detection Limit (MDL)** - The minimum concentration of an analyte that can be identified, measured, and reported with 99% confidence that the analyte concentration is greater than zero.
- 3.45. **Mixing Volume** - Spherical bottle in which sample gases become homogenous.
- 3.46. **Mother Board** - The main printed circuit board. All CE-440 power supplies are located here.
- 3.47. **Must** - Denotes a requirement that must be met. (Random House College Dictionary)

- 3.48. **Precision** - The degree to which a set of observations or measurements of the same property, obtained under similar conditions, conform to themselves; a data quality indicator. Precision is usually expressed as standard deviation, variance or range, in either absolute or relative terms. (NELAC)
- 3.49. **Preservation** – Refrigeration, freezing and/or reagents added at the time of sample collection (or later) to maintain the chemical and or biological integrity of the sample.
- 3.50. **Pressure Transducer** - Used to check for leaks in the system and to monitor pressure in the mixing volume.
- 3.51. **P Valve** - The valve on the injector box of the horizontal auto-injector (HA) used to automatically purge the box.
- 3.52. **Profile** - Generated by the bridge signal. Used to help determine if a leak or malfunction occurs in the system.
- 3.53. **Quality Control Sample (QCS)** - A sample of analytes of known and certified concentrations. The QCS is obtained from a source external to the laboratory and different from the source of calibration standards. It is used to check laboratory performance with externally prepared test materials. Also referred to as CRM.
- 3.54. **Reduction Tube** - Quartz tube with reduced copper that removes excess oxygen from the sample gas and reduces oxides of nitrogen to free nitrogen.
- 3.55. **Response Factor (RF)** - The ratio of the response of the instrument to a known amount of analyte.
- 3.56. **Run** - One full sample analysis from start to finish, including printout.
- 3.57. **Run Cycle** - Typically a day or half day of operation - the entire analytical sequence of runs from the first run to the last run on the Sample Wheel.
- 3.58. **Sample Volume** - Tube where sample gas is exhausted from the mixing volume prior to entering the detector.
- 3.59. **Sample Wheel** – Sample holding device which contains up to 64 blanks, standards and samples. One wheel equals roughly 6 hours of run time, which is called the Run Cycle.
- 3.60. **Scrubber** - Removes water and carbon dioxide from the gas supplies.
- 3.61. **Sediment (or Soil) Sample** - A fluvial, sand, or humic sample matrix exposed to a marine, estuarine or fresh water environment.
- 3.62. **Sensitivity** - The capability of a test method or instrument to discriminate between measurement responses representing different levels (concentrations) of a variable of interest.
- 3.63. **Shall** - Denotes a requirement that is mandatory whenever the criterion for conformance with the specification requires that there be no deviation. (ANSI)
- 3.64. **Should** - Denotes a guideline or recommendation whenever noncompliance with the specification is permissible. (ANSI)
- 3.65. **Sleeve** - Nickel - to maintain integrity of the sample capsule and to protect the quartz ware from devitrification (to destroy the glassy qualities by prolonged heating).
- 3.66. **Standard Reference Material (SRM)** - Material which has been certified for specific analytes by a variety of analytical techniques and/or by numerous laboratories using similar analytical techniques. These may consist of pure chemicals, buffers, or compositional standards. The materials are used as an

indication of the accuracy of a specific analytical technique. Also referred to as CRM.

- 3.67. **Trap** - Used for removing water and CO₂ from the sample gas.
- 3.68. **Tissue sample** – Plant or animal tissue dried and ground ready for weighing.
- 3.69. **Zero Value** - Bridge signal with only pure helium flowing through the detector.

4. INTERFERENCES







- 4.1. There are no known interferences for fresh, estuarine or coastal water or sediment samples. The presence of C and N compounds on laboratory surfaces, on fingers, in detergents and in dust necessitates the utilization of careful techniques (i.e., the use of forceps and gloves) to avoid contamination in every portion of this procedure (EPA.)

5. SAFETY

- 5.1. Safety precautions must be taken when handling reagents, samples and equipment in the laboratory. Protective clothing including lab coats and safety glasses and enclosed shoes must always be worn. In certain situations it may also be necessary to use gloves and goggles. If solutions or chemicals come in contact with eyes, flush with water continuously for 15 minutes. If solutions or chemicals come in contact with skin, wash thoroughly with soap and water. Contact Solomons Rescue Squad (911) if emergency treatment is needed. Inform the CBL Associate Director of Facilities and Maintenance of the incident if additional treatment is required.
- 5.2. The toxicity or carcinogenicity of each reagent used in this procedure may not have been fully established. Each chemical should be regarded as a potential health hazard and exposure should be as low as reasonably achievable. Cautions are included for known extremely hazardous materials and procedures.
- 5.3. High current and voltages are exposed near the furnaces, furnace control card, and mother board even while the CE-440 is OFF. If non-electrical trouble shooting is desired, remove the CE-440 line cord from the wall receptacle.
- 5.4. The combustion tube is brittle since it is fused quartz. Do not put any unnecessary stress on it.
- 5.5. The exterior of the furnace becomes extremely hot; do not touch it or the heat shield unless wearing appropriate gloves.
- 5.6. Do not wear any jewelry if electrically troubleshooting. Even the low voltage points are dangerous and can injure if allowed to short circuit.
- 5.7. The following hazard classifications are listed for the chemicals regularly used in this procedure.

TABLE 1.

Chemical	Health Hazard	Fire Hazard	Instability Hazard	Specific Hazard	
----------	---------------	-------------	--------------------	-----------------	--

Acetanilide	1	1	0		
Atropine	4	0	0		
Magnesium Perchlorate	2	0	2	OX	 
Ascarite (Sodium Hydroxide)	3	0	0	ALK, COR	
Silver vanadate on Chromosorb	3	0	0		
Silver oxide/Silver tungstate on Chromosorb	1	0	0		
Silver tungstate/Magnesium oxide on Chromosorb	0	0	0		
Copper wire	0	0	0		
<p>On a scale of 0 to 4 the substance is rated on four hazard categories: health, flammability, reactivity, and contact. (0 is non-hazardous and 4 is extremely hazardous)</p> <p><u>HAZARD RATING</u></p> <p>Health Hazard - Blue: 4 – deadly, 3 – extreme danger, 2 – hazardous, 1 – slightly hazardous, 0 – normal material</p> <p>Fire Hazard - Red: Flash Points: 4 – below 73° F, 3 – below 100° F, 2 – below 200° F, 1 – above 200° F, 0 – will not burn</p> <p>Instability Hazard - Yellow: 4 – may detonate, 3 – Shock and heat may detonate, 2 – violent chemical change, 1 – unstable if heated, 0 - stable</p> <p>Specific Hazard - White: Acid = ACID, Alkali = ALK, Corrosive = COR, Oxidizer = OXY</p>					

6. EQUIPMENT AND SUPPLIES

- 6.1. An elemental analyzer capable of maintaining a combustion temperature of 980°C and analyzing particulate and sediment samples for elemental carbon and nitrogen. The Exeter Model CE-440 is used in this laboratory.
- 6.2. A gravity convection drying oven, capable of maintaining 47°C ± 2°C for extended periods of time.
- 6.3. Muffle furnace, capable of maintaining 900°C +/- 15°C.
- 6.4. Ultra-micro balance that is capable of accurately weighing to 0.1 ug.
- 6.5. Vacuum pump or source capable of maintaining up to 10 in. Hg of vacuum.
- 6.6. Freezer, capable of maintaining -20°C± 5°C.
- 6.7. 25-mm vacuum filter apparatus made up of a glass or plastic filter tower, fritted glass or plastic disk base and 2-L vacuum flask.
- 6.8. Flat blade forceps.

- 6.9. Labware - All reusable labware (glass, quartz, polyethylene, PTFE, FEP, etc.) must be sufficiently clean for the task objectives. Clean glassware by rinsing with reagent water; soaking for 4 hours or more in 10% (v/v) HCl and then rinsing with reagent water. Store clean. All traces of organic material must be removed to prevent carbon and nitrogen contamination.

7. REAGENTS AND STANDARDS

- 7.1. **Purity of Water** – Unless otherwise indicated, references to water shall be understood to mean reagent water conforming to ASTM Specification D 1193, Type I.
- 7.2. **Purity of Reagents** – Reagent grade chemicals shall be used in all tests. Unless otherwise indicated, it is intended that all reagents shall conform to the specifications of the Committee on Analytical Reagents of the American Chemical Society, where such specifications are available. Other grades may be used, provided it is first ascertained that the reagent is of sufficiently high purity to permit its use without lessening the accuracy of the determination.
- 7.3. **Acetanilide, 99.9% + purity**, C₈H₉NO (CASRN 103-84-4) - ACS grade acetanilide; primary standard used to calibrate the instrument
- 7.4. **Blanks** – Three blanks are used for the analysis. Two blanks are instrument related. The *instrument zero* response (ZN) is the background response of the instrument without sample holding devices such as capsules and sleeves. The *instrument blank* response (BN) is the response of the instrument when the sample capsule, sleeve and ladle are inserted for analysis without standard or sample. The is also the laboratory reagent blank (LRB) for standards and sediment or other weighed samples. The LRB for water samples includes the sleeve, ladle and a pre-combusted filter without standard or sample. These blanks are subtracted from the uncorrected instrument response used to calculate concentration. The third blank is the *laboratory fortified blank* (LFB.) For all sample analysis, a weighed amount of atropine or other certified standard is placed in an aluminum capsule and analyzed. The LFB may need to be recalculated with the correct instrument blank; this is dependent on the type of samples being analyzed and the original instrument blank type.
- 7.5. **Quality Control Sample (QCS)** – For this procedure, the QCS can be any assayed and certified sediment or particulate sample which is obtained from an external source. PACS-2 from the National Research Council of Canada is used by this laboratory. The laboratory fortified blank may also be considered a QCS.

8. SAMPLE COLLECTION, PRESERVATION AND STORAGE

- 8.1. **Water Sample Collection** – Samples collected for PNC analysis from fresh, estuarine and coastal waters are normally collected from a boat or pier using one of two methods; hydrocast or submersible pump systems. Follow the recommended sampling protocols associated with the method used. Whenever

possible, immediately filter the samples as described in Section 11.1.1. Store the filtered sample in a labeled aluminum foil pouch and freeze at -20°C or store in a low temperature (47°C) drying oven after drying at 47°C ± 2°C, until use. If storage of the unfiltered water sample is necessary, place the sample into a clean bottle and store at 4°C until filtration is performed. Filter samples within 24 hours. Dry samples in a low temperature (47°C+/-2°C) drying oven prior to analysis.

- 8.2. The volume of water sample collected will vary with the type of sample being analyzed. Table 2 below provides a guide for a number of matrices of interest. If the matrix cannot be classified by this guide, collect 1 L of water from each site.
- 8.3. Sediment, Tissue, or Soil Sample Collection – Sediment samples are collected with benthic samplers. The type of sampler used will depend on the type of sample needed by the data-quality objectives. Tissue and soil samples are collected by a variety of methods. Store the wet sample in a clean labeled jar and freeze at -20°C until ready for analysis. Dry samples in a low temperature (47°C+/-2°C) drying oven, and grind to a homogenous powder with a mortar and pestle, prior to analysis.
 - 8.3.1. The amount of solid material collected will depend on the sample matrix. A minimum of 1 g is recommended.
 - 8.3.2. Filtration Volume Selection Guide

TABLE 2.

Sample Matrix	25mm Filter
Open Ocean	500 – 1000 ml
Coastal	400 – 500 ml
Estuarine (Low particulate)	250 – 400 ml
Estuarine (High Particulate)	25 – 200 ml

9. QUALITY CONTROL

- 9.1. The laboratory is required to operate a formal quality control (QC) program. The minimum requirements of this program consist of an initial demonstration of laboratory capability and the continued analysis of laboratory instrument blanks, field duplicates, and standards analyzed as samples as a continuing check on performance. The laboratory is required to maintain performance records that define the quality of data generated.

9.2. Initial Demonstration of Capability

- 9.2.1. **The initial demonstration of capability (DOC)** – is used to characterize instrument performance (MDLs) and laboratory performance (analysis of QC samples) prior to the analyses conducted by this procedure.
- 9.2.2. **Quality Control Sample (QCS/SRM)** – When using this procedure, a quality control sample is required to be analyzed at the middle and end of the run (along with CCV standards) to verify data quality and acceptable instrument performance. If the determined concentrations are not within $\pm 3\sigma$ of the certified values, performance of the determinative step of the method is unacceptable. The source of the problem must be identified and corrected before proceeding with the initial determination of MDLs. It is possible the QCS/SRM may fall above or below control limits but still passes within $\pm 10\%$ of the certified values. This is still within acceptance limits.
- 9.2.3. **Method Detection Limits (MDLs)** – MDLs should be established for aqueous particulate carbon and nitrogen using a low level natural water sample. The same procedure should be followed for sediments or other weighed samples. To determine the MDL values, analyze seven replicates and process through the entire analytical procedure. Calculate the MDL as follows:

$$\text{MDL} = S t_{(n-1, 1-\alpha=0.99)}$$

Where,

S = Standard deviation of the replicate analyses.

n=number of replicates

$t_{(n-1, 1-\alpha=0.99)}$ = Student's *t* value for the 99% confidence level with n-1 degrees of freedom ($t=3.14$ for 7 replicates.)

- 9.2.4. MDLs should be determined annually, whenever there is a significant change in instrumental response or a new matrix is encountered.

9.3. Assessing Laboratory Performance

- 9.3.1. **Laboratory Reagent Blank (LRB)** – The laboratory must analyze at least one LRB (Section 3.37) with each batch of samples. For sediment samples the LRB consists of the ladle, sample sleeve and sample capsule, as there are no reagents involved in this procedure. For aqueous samples, the LRB consists of the ladle, sample sleeve and a pre-combusted filter of the same type and size used for samples. LRB data are used to assess contamination from the laboratory environment. For sediment samples, the blank value for carbon should not exceed $150\mu\text{v}$ and the blank value for nitrogen should not exceed $15\mu\text{v}$. For aqueous samples, the blank value for carbon should not exceed $300\mu\text{v}$ and the blank value for nitrogen should not exceed $15\mu\text{v}$.

- 9.3.1.1. If the nitrogen blank during a BLANK analysis is in excess of 2000% the nitrogen blank in memory the “COPPER APPEARS SPENT” warning is printed. If the nitrogen blank increased over $100\mu\text{v}$ over BN in memory and the first STANDARD KC/KN is more than any following STANDARD KC/KN by $0.2\mu\text{v}/\text{ug}$, then a “COPPER APPEARS SPENT” warning will be printed either during a BLANK analysis or a STANDARD analysis. Maintenance will be required.

9.3.1.2. The Reagent Blank Control Chart is constructed from the average and standard deviation of Reagent Blank measurements recorded annually. This includes both filter pad blanks and capsule blanks. The accuracy chart includes upper and lower warning levels ($WL = \pm 2s$) and upper and lower control levels ($CL = \pm 3s$). The standard deviation (s) is specified relative to statistical confidence levels of 95% for WLs and 99% for CLs. Enter Reagent Blank results on the chart each time the Reagent Blank is analyzed.

9.3.2. **Quality Control Sample (QCS)/ Standard Reference Material (SRM)** - When using this procedure, a quality control sample is required to be analyzed at the middle and end of the run, to verify data quality and acceptable instrument performance. The QCS will be obtained from a source external to the laboratory and different from the source of calibration standards. If the determined concentrations are not within $\pm 3\sigma$ of the certified values, performance of the determinative step of the method is unacceptable. The source of the problem must be identified and corrected before either proceeding with the initial determination of MDLs or continuing with the analyses. Corrective action documentation is required for all data outside $\pm 3\sigma$. The standard deviation data should be used to establish an on-going precision statement for the level of concentrations included in the QCS. This data must be kept on file and be available for review. Values for QCSs should be plotted with the other control data. The sample weight of the SRM should mirror that of the unknown samples (~10 mg).

9.3.2.1. The Accuracy Control Chart for QCS/SRM samples is constructed from the average and standard deviation of QCS/SRM measurements recorded annually. The accuracy chart includes upper and lower warning levels ($WL = \pm 2s$) and upper and lower control levels ($CL = \pm 3s$). These values are derived from stated values of the QCS/SRM. The standard deviation (s) is specified relative to statistical confidence levels of 95% for WLs and 99% for CLs. Set up an accuracy chart by using $\pm 10\%$ in addition to $\pm 3s$ since the concentration of the QCS/SRM varies. Enter QCS/SRM results on the chart each time the sample is analyzed.

9.4. **Assessing Analyte Recovery** - Percent recoveries cannot be readily obtained from particulate samples. Consequently, accuracy can only be assessed by analyzing check standards as samples (CCV, QCS/SRM).

9.5. **Data Assessment and Acceptance Criteria for Quality Control Measures**

TABLE 3.

QC INDICATOR	ACCEPTANCE LIMITS	ACTION	FREQUENCY (BATCH)
K-factor	KC = 18 to 25 18 to 25 $\mu\text{v}/\mu\text{g}$ is manufacturer's recommended limits. KN = 7 to 10 $\mu\text{v}/\mu\text{g}$	The k-factors must be within the specified limits or the standard must be reanalyzed. (see 10.3)	3 per batch to acquire an acceptable K-factor calibration range.

	7 to 10 $\mu\text{v}/\mu$ is manufacturer's recommended limits.		
Initial Calibration Verification (ICV)	$\pm 10\%$	Qualify data if not within acceptance limits. Rejection criteria for batch.	At the beginning of a run immediately following the calibration.
Quality Control Sample (QCS)/ Certified Reference Material (CRM)	$\pm 10\%$	If QCS is outside acceptance limits, qualify the data for all samples back to last acceptable QCS.	After every 25 samples.
Continuing Calibration Verification (CCV)	$\pm 10\%$	Qualify data if not within acceptance limits. Rejection criteria for batch. May be CRM or Atropine standard.	After every 25 samples.
Method Blank/Laboratory Reagent Blank (LRB)	<i>Filter Pad Blanks:</i> BC < 300 μv BN < 15 μv <i>Capsule Blanks:</i> BC < 150 μv BN < 15 μv	If the blank value is greater the acceptable value, replace and rerun the blanks.	At the beginning and end of a run. LRB may be a filter pad or capsule blank.
Field Duplicate	$\pm 30\%$	Duplicate sample data must be within $\pm 30\%$ or be qualified. All duplicates for this procedure are field duplicates and are more a measure of field collection and filtration techniques.	

9.6. Corrective Actions for Out-Of-Control Data

- 9.6.1. All samples must be qualified when external QC samples are out of control.
- 9.6.2. All samples between QCSs that are out of control must be qualified.
- 9.6.3. All problems with analytical runs must be documented on the bench sheet.

9.7. General Operation

- 9.7.1. To assure optimal operation and analytical results, it is advisable to track the stability of the instrument. Of primary importance is the precision and repeatability of standard and blank values during the course of a day of operation. Thus, a standard (as an unknown) should be inserted approximately every twenty five samples. Try to use different standards for QA in order to assure the validity of the calibration values over the entire operating range of the instrument.

10. CALIBRATION, STANDARDIZATION and CALCULATIONS

- 10.1. Calibration - Daily calibration procedures must be performed and evaluated before sample analysis may begin. Single point calibration is used with the Exeter Model CE-440 Analyzer.
- 10.2. Establish single calibration factors (K) for each element (carbon, hydrogen, and nitrogen) by analyzing three weighed portions of calibration standard (acetanilide). The mass of the calibration standard should provide a response within 20% of the

response expected for the samples being analyzed. Calculate the (K) for each element using the following formula:

$$Kfactor (\mu v / \mu g) = \frac{RN - ZN - BN}{M(T)}$$

Where: RN = Instrument response to standard (μv)
 ZN = Instrument zero response (μv)
 BN = Instrument blank response (μv)
 M = Mass of standard matter in μg
 T = Theoretical % C, N, or H in the standard. For acetanilide %C = 71.09, %N = 10.36 and %H = 6.71.

10.3. The detector generates a signal directly proportional to the compound of interest in the sample. The following formula is used to calculate carbon, nitrogen and hydrogen concentrations in unknown samples.

$$\% = \frac{1}{K} \times \frac{1}{W} \times (R - Z - B) \times 100$$

Where

K = calibration factor for the 440 instrument
 W = sample weight
 R = read signal of sample gas
 Z = zero reading or base line of instrument
 B = blank signal generated by instrument itself, including ladle and capsules

10.4. The K-factor is established by running samples of a known standard. The default value is for acetanilide, which is used as the standard:

Acetanilide C = 71.09% H = 6.71% N = 10.36%

If another standard is used, the values will need to be entered into the computer using the Edit Standards function in the Customizing Menu.

- 10.4.1. Once the blank values have been established and entered into memory, proceed to run known standards to arrive at the calibration factors for carbon and nitrogen for the instrument.
- 10.4.2. Run a minimum of three standards, average the results, and enter into computer memory, or use the automatic enter mode. During the run, standards may be entered as samples to verify the K-factors and blanks.
- 10.4.3. Any time a STD1 is entered as sample ID the computer calculates and enters a new set of operating Ks based on a weighted formula using the last three sets of Ks in memory. This occurs only if all three Ks fall within the following windows:

$$\begin{aligned} \text{New KC} &= \text{KC in memory} \pm 1.0 \\ \text{KN} &= \text{KN in memory} \pm 0.5 \end{aligned}$$

10.4.3.1. It is important that the Ks in memory be close to expected values or new Ks generated will not be within the window and therefore will not be accepted for automatic insertion.

10.4.3.2. The weighted formula for calculating the Ks:

$$K = k^1 + (0.5 \times k^2) + \frac{(0.25 \times k^3)}{1.75}$$

where:

k^1 = k found in this run

k^2 = Next k in memory

k^3 = Last k in memory

10.5. **Conditioner** - Before injecting any samples or blanks, it is necessary to run one or more conditioners. The purpose of the conditioner runs is to coat the walls of the system surfaces, especially the mixing and sample volume, with water vapor, carbon dioxide and nitrogen which simulates actual sample running conditions. To simulate this condition as closely as possible, it is advisable to use conditioners of approximately the same weight as the samples. Always inject a conditioner before a standard.

10.6. **Blanks** - The blank value used in the calculation is the total signal generated by the system including the ladle and sample capsule. This blank should always be analyzed immediately after a weighed conditioner to represent a true blank of the instrument. Never use the blank value from an empty wheel since the system dries up and the blank value would be lower than normal. The instrument program will only accept blanks if they fall within the following:

New BC < 500

New BN < 250

10.7. **K-Factors** - Once the blank values have been established and entered into memory, proceed to run known standards (acetanilide) in order to establish the calibration factors for carbon, hydrogen and nitrogen. The computer will calculate K-factors as long as STD# has been entered as the sample ID. Run a minimum of three (3) standards, average the results, and enter into the computer memory, or use the automatic enter mode. To verify that the instrument is running well, all the individual K-Factor values should be within +/- 0.08 of the mean. The instrument is now ready to analyze samples. Acetanilide standards may be analyzed as unknowns verify the K-factors and blank values; atropine and PACS-2 already serve as a calibration check and are analyzed throughout the run cycle.

11. PROCEDURE

11.1. Aqueous Sample Preparation

11.1.1. Water Sample Filtration

Pre-combust 25-mm GF/F glass fiber filters at 500°C for 1.5 hours. Store filters covered, if not immediately used. Place a pre-combusted filter on a fritted filter base of the filtration apparatus and attach the filtration tower. Thoroughly shake the sample container to suspend the particulate matter. Measure and record the

required sample volume using a graduated cylinder. Pour the measured sample into the filtration tower. Filter the sample using a vacuum no greater than 10 in. of Hg. Vacuum levels greater than 10 in. of Hg can cause cell rupture. Do not rinse the filter following filtration. It has been demonstrated that sample loss occurs when the filter is rinsed with an isotonic solution or the filtrate. Air dry the filter after the sample has passed through by continuing the vacuum for 30 sec. Using flat-tipped forceps, fold the filters in half while still on the base of the filter apparatus. Store filters as described in Section 8.1.

11.1.2. If the sample has been stored frozen in foil pouches, place in a drying oven at $47^{\circ}\text{C} \pm 2^{\circ}\text{C}$ for 24 hours before analysis. Slightly open the pouch to allow drying. When ready to analyze, fold, and insert the filter into a pre-combusted nickel sleeve using forceps. Tap the filter pad down into the nickel sleeve using a clean stainless steel rod. The sample is ready for analysis.

11.2. Sample Analysis

11.2.1. As the filters are packed into the nickel sleeves they are placed into the 64 position sample wheel. The calibration series must be placed at the beginning of the batch. The sample schedule consists of a conditioner, a blank, a conditioner and three standards. ACS grade acetanilide 99.9% + purity must be used to calibrate the instrument.

11.2.2. Set up the sample tray in the following manner (used for aqueous samples):

TABLE 4.

Position #	Contents	Notes	Type	Weight, ug
1	Conditioner	Acetanilide (1500-2500 μg)	Conditioner	Weight of Acetanilide
2	Capsule + sleeve	Blank	Blank	0
3	Capsule + sleeve	Blank	Blank	0
4	Conditioner	Acetanilide (1500-2500 μg)	Conditioner	Weight of Acetanilide
5	Standard	Acetanilide (1500-2500 μg)	STD1 ^a	Weight of Acetanilide
6	Standard	Acetanilide (1500-2500 μg)	STD1	Weight of Acetanilide
7	Standard	Acetanilide (1500-2500 μg)	STD1	Weight of Acetanilide
8	Sleeve +capsule+ standard	Atropine (1500-2500ug)	LFB	Weight of Atropine
9	Sleeve + filter pad	Filter Blank	LRB	0
10-34	Samples			Volume filtered/10
35	Sleeve +capsule+ standard	PACS-2 (8000-15,000ug)	QCS/SRM	Weight of PACS-2
36-60	Samples			Volume filtered/10
61	Capsule + Sleeve	Blank	Blank	0
62	Sleeve + capsule+ standard	Atropine (1500-2500ug)	LFB	Weight of Atropine
63	Sleeve + capsule+ standard	PACS-2 (8000-15,000ug)	QCS/SRM	Weight of PACS-2
64	Capsule + Sleeve	Blank	Blank	0

^a Always use STD1 in the Standard position. The system recognizes this as acetanilide and makes the appropriate calculations for the K factor.

11.2.3. By entering volume filtered/10 for the weight of the aqueous filtered samples, results printed out represent micrograms of carbon or nitrogen per liter. This corresponds directly to the known amount of liquid that has passed through the filter. The maximum sample capacity per run is approximately 4,000 to 5,000 micrograms of carbon on the filter pad. Filters containing more than that amount may be cut in half and analyzed separately and the results added.

11.2.4. Filter Preparation for Analysis

11.2.4.1. Work on a clean, non-contaminating surface.

11.2.4.2. Using two pairs of clean forceps, fold the filter in half so that the exposed surface is inside. Continue folding the filter in half until you have a compact package.

11.2.4.3. Place a pre-combusted 7 x 5 mm nickel sleeve into the filter loading die, which functions as a holding device. Use the clean 4 mm loading rod to force the compressed filter through the clean loading funnel and into the nickel sleeve.

11.2.4.4. Make sure no excess filter protrudes above the lip of the sleeve.

11.2.4.5. Place loaded sleeve in the 64-sample wheel.

11.2.5. Determination of Particulate Organic and Inorganic Carbon

11.2.5.1. Thermal Partitioning is the method used to partition organic and inorganic carbon. The difference found between replicate samples, one of which has been analyzed for total PC and PN and the other of which was muffled at 550°C for three hours to drive off organic compounds, and then analyzed for PC and PN, is the particulate organic component of that sample. This method of thermally partitioning organic and inorganic PC may underestimate slightly the carbonate minerals' contribution in the inorganic fraction since some carbonate minerals decompose below 500°C, although CaCO₃ does not. This method is used for filtered samples where at least two filters per sample must be supplied. For sediment samples at least 1 g of sample is required and at least 0.5g of sample is weighed into a crucible of known weight. The weight is recorded. The crucible is then muffled as above, and weighed again. The percent remaining of the ash is calculated and multiplied times the %C in the ash which is then determined by the CE-440.

12. DATA ANALYSIS AND CALCULATIONS

12.1. Raw results are printed. These data are then exported from the instrument computer to the analyst computer by a flash drive. The data is then entered into an Excel spreadsheet. Results are reported in mg/L for aqueous samples, and in % for sediment or other weighed samples, standards and SRMs or QCSs.

12.2. Recalculation of data (if necessary)

12.2.1. The software gives the analyst the opportunity to recalculate values generated by the run. This option can be useful for adjusting the values of the data due to explained or unexpected changes in the blank or calibration (K) factor

during an analytical run cycle. Blanks can change due to sample handling, different capsules or sleeves, small leaks in the system and contamination. K factors should remain stable but can drift due to flow changes caused by variable pressure drops in the traps or helium scrubber, or by changing delivery pressure at the helium regulator.

12.2.2. Before the analyst can change calibration values and recalculate the results, there must be a valid reason. When data is recalculated, always document the incident.

12.3. Example of Excel spreadsheet of results:

	A	B	C	D	E	F	G
1	3/31/2017						
2	ANALYST NAME						
3	CLIENT						
4	RECEIVED DATE						
5							
6	SAMPLE ID	PC, mg C/L	PN, mg N/L	ERROR			
7	SAMPLE1	0.8340	0.1420				
8	SAMPLE2	0.7070	0.1090				
9	SAMPLE3	0.6600	0.1010				
10	SAMPLE4	0.6890	0.1030				
11	SAMPLE5	0.7720	0.0869				
12	SAMPLE6	0.2600	0.0513				
13	SAMPLE7	0.2720	0.0435				
14	SAMPLE BLANK	0.00	0.00	ug/pad			
15							
16	LAB DUPS	PC, mg C/L		PN, mg N/L			
17	SAMPLE ID	DUP 1	DUP 2	DUP 1	DUP 2		
18	SAMPLE4	0.7000	0.6780	0.1070	0.0993		
19							
20	BLANKS C=	235	K VALUES C=	22.097			
21	N=	9	N=	8.055			
22							
23	QC NAME	ACTUAL		EXPECTED		% RECOVERY	
24		%C	%N	%C	%N	%C	%N
25	ATROPINE	69.21	4.81	70.56	4.84	98.1	99.4
26	ATROPINE	70.40	4.93	70.56	4.84	99.8	101.9
27	PACS2	3.24	0.29	3.21	0.29	100.9	100.0

12.3.1. Cell 1A - Analysis date

12.3.2. Cell 2A – Analyst’s name

12.3.3. Cell 3A – Sample source or client

12.3.4. Cell 4A – Sample or Received date

12.3.5. Cell 6A – Column heading for Sample

12.3.6. Cell 6B – Column heading for C concentration

12.3.7. Cell 6C – Column heading for N concentration

12.3.8. Cell 6D – Column heading for errors and qualifiers

12.3.9. Cells 7A to 14D – Sample Results table

- 12.3.10. Cells 16A to 18E – QC table for field duplicates. The mean of these values is reported in the sample results table
- 12.3.11. Cells 20A to 21D – Instrument values for the Blanks and Ks.
- 12.3.12. Cells 23A to 27G- Values for CCV/QCS/SRM samples and percent recoveries for each day of analyses.
- 12.4. Sample data should be reported in units of mg/L as carbon or nitrogen for aqueous samples, and as percent carbon or nitrogen for sediment samples.
- 12.5. Report analyte concentrations to three significant figures for both aqueous and sediment samples.
- 12.6. For aqueous samples, calculate the sample concentration using the following formula:
- $$\text{Concentration (mg / L)} = \frac{\text{Corrected sample response}(\mu\text{g / L})}{1000\mu\text{g / mg}}$$
- 12.7. For weighed samples, % N or %C are already calculated by the instrument software.

13. **POLLUTION PREVENTION**

- 13.2. Pollution prevention encompasses any technique that reduces or eliminates the quantity of toxicity of waste at the point of generation. Numerous opportunities for pollution prevention exist in laboratory operation. The USEPA has established a preferred hierarchy of environmental management techniques that places pollution as the management option of first choice. Whenever feasible, laboratory personnel should use pollution prevention techniques to address their waste generation. When wastes cannot be feasibly reduced at the source, the agency recommends recycling as the next best option.
- 13.3. For information about pollution prevention that may be applicable to laboratories and research institutions, consult “Less is Better: Laboratory Chemical Management for Waste Reduction”, available from the American Chemical Society, Department of Government Relations and Science Policy, 1155 16th Street N. W., Washington, D.C. 20036.

14. **WASTE MANAGEMENT**

- 14.1. The reagents used in this procedure are minimal and are not hazardous with the exception of the ascarite and magnesium perchlorate. Due to the small quantity of ascarite and magnesium perchlorate used, the spent reagent can be flushed down the drain with running water.
- 14.2. For further information on waste management consult The Waste Management Manual for Laboratory Personnel, available from the American Chemical Society.

15. **REFERENCES**

- 15.1. U.S. Environmental Protection Agency, 1997. Methods for the Determination of Chemical Substances in Marine and Estuarine Environmental Samples. Method 440.0. U.S. Environmental Protection Agency. Washington, D.C.
- 15.2. Holme, N.A. and A.D. McIntyre (eds.). 1971. Methods for the Study of Marine Benthos. International Biome Program. IBP Handbook #16. F.A. Davis Co., Philadelphia, PA.
- 15.3. Hurd, D.C. and D.W. Spencer (eds). 1991. Marine Particles: Analysis and Characterization. Geophysical Monograph: 63, American Geophysical Union, Washington, D.C. 472p.
- 15.4. Hirota, J. and J.P. Szyper. 1975. Separation of total particulate carbon into inorganic and organic components. *Limnol and Oceanogr.* 20:896-900.
- 15.5. Grasshoff, K., M. Ehrhardt and K. Kremlin (eds). 1983. Methods of Seawater Analysis. Verlag Chemie.
- 15.6. Keefe, Carolyn W., The Contribution of Inorganic Compounds to the Particulate Carbon, Nitrogen and Phosphorus in Suspended Matter and Surface Sediments of the Chesapeake Bay, *Estuaries*, Vol. 17, No 1B, pp 122-130, March 1994.
- 15.7. 40 CFR, Part 136, Appendix B. Definition and Procedure for the Determination of the Method Detection Limit. Revision 1.11.
- 15.8. Zimmermann, C. F., Keefe, C. W., and Bashe, J. 1997. Method 440.0. Determination of Carbon and Nitrogen in Sediments and Particulates of Estuarine/Coastal Waters Using Elemental Analysis. USEPA

TABLE 5

PC/IPN BENCH SHEET							
WHEEL LABEL: ANALYST:				PREP DATE: ANALYSIS DATE:			
HOLE NO	ID	VOL OR WT	ADDITIONAL	HOLE NO	ID	VOL OR WT	ADDITIONAL
1	COND			51			
2	CAP BL			52			
3	CAP BL			53			
4	COND			54			
5	STD1			55			
6	STD1			56			
7	STD1			57			
8	ICV ATROPINE			58			
9	ICB FP BL			59			
10				60			
11				61	CAP BL		
12				62	CCV ATROPINE		
13				63	CRM PACS2		
14				64	CAP BL		
15							
16							
17					ACETANILIDE LOT#	B0137476	
18					ATROPINE LOT#	YF0611	
19					CRM LOT#	PACS2	
20							
21							
22							
23							
24							
25							
26							
27							
28							
29							
30							
31							
32							
33							
34							
35	CRM PACS2						
36							
37							
38							
39							
40							
41							
42							
43							
44							
45							
46							
47							
48							
49							
50							
FILES CREATED:				Exeter Analytical CE440			

Appendix

Initial Start-Up

The following sequence should be followed when initially starting up the Exeter CE-440 Elemental Analyzer or when restarting after a shutdown. Make sure the power switches on the computer and on the CEC- 490 (Interface) are off. Remove the CE-440 cover from instrument. Check that the helium regulator is set at 18 psig and oxygen at 20 psig and open the in-line gas valves. If restarting, check that the combustion and reduction tubes, scrubber and traps are not exhausted. Turn the selector switch to SYSTEM. Turn on the CEC-490 and the computer. If this is a cold re-start, set combustion and reduction furnace temperature controls to values previously established. Wait until the reduction furnace has reached operating temperature. **DO NOT PUSH DETECTOR RESET BUTTON AT THIS TIME!** If the tubes need to be replaced, go to “Tube Replacement” in the Service Menu, then follow the directions under “Combustion Tube Replacement” to purge the helium and oxygen regulators twice. This will also serve the purpose of conditioning the reduction and combustion tubes. Then go to Main Menu and install the end connectors.

After allowing the CE-440 oven to reach operating temperature (about one hour) go to the Service Menu and select Calibrate CEC-490. Calibrate all and follow instructions. Run 2 to 3 blanks to establish a fill time of about 20 to 40 seconds. If the fill time has been exceeded, increase the helium pressure and repeat this step until fill time is achieved. Helium pressure should be at about 12-18 psig. (This is dependent on regulator type.) If the system still aborts, go through the leak test mode.

Make certain that helium gas is flowing by checking that the tank is open and the regulator is set to the correct pressure before pressing the DETECTOR RESET button. After the first accepted blank, push DETECTOR RESET. High concentrations of air or oxygen in the system will damage the filaments in the detectors if power is applied. To protect the detectors, a detector safety circuit is provided which shuts off power when the helium carrier gas becomes contaminated with air or oxygen at levels generating an imbalance of about 450 μ v or higher. The safety circuit will activate should leaks develop or when the helium supply is depleted. The safety circuit monitors the gross imbalance between the two sides of the nitrogen bridge. If air or oxygen is present on both sides of the bridge, the safety circuit may not activate and damage to the detectors may occur. The safety circuit is also activated when accidental or deliberate power interruption occurs. If power has been interrupted for more than 5 minutes, do not push DETECTOR RESET until the system has performed a blank run. Do not hold the DETECTOR RESET button in more than one second. If the light stays on when the button is released, continue with additional blank runs as necessary before pushing the button again. Go through one blank run before turning on the detector.

Once the detector has been reset, go to the Service Menu and monitor the bridge readings. Adjust the “zero” reading to approximately 2500 μ v by turning the respective potentiometers on the Bridge Balance Card located in the left rear corner of the Motherboard. (To access these systems, the instrument cover must be removed.) Typically the bridges should be set well above negative or zero (approximately + 2500 μ v). This is after the instrument has stabilized. Stability is based on furnace and oven temperatures being steady for a period of

not less than 1 hour. Check the furnace and oven temperatures. If these have reached operating levels, let the instrument go through another three sets of blanks in order to purge the system and condition the reagents. This can be done through the CHN Run Mode (Run Menu). Make sure the B-valve is ON to run oxygen and run blanks until (a) BC and BN are less than 200 μ v and BH is less than 1500 μ v, and (b) consecutive BC/BN agrees to 10 μ v and BH to 50 μ v. It may take time for BH to settle. Go to the Service pull down Menu and calibrate all of the CEC-490 again. The instrument is now ready for system calibration with known standards.

Standby Mode

To reduce helium consumption and minimize wear on the terminal screen, the overnight standby mode is used. Select the overnight standby mode (in the Run pull-down menu). To return to normal operation, select Stop Overnight Standby.

Powering Down

It is preferable for the system to remain powered up at all times since this will extend the life time of the glassware, reagents, and electronics. However, helium and power will be consumed during this standby and it might be necessary to power down the CE-440 instrument. To assure minimum disruption for a future start up after a power down, proceed as follows:

- Turn the furnace temperature controllers to zero.
- Allow several hours for the furnace temperatures to drop below 100°C.
- Turn off the power to the instrument as well as gas valves between the instrument and the regulators.
- Turn off the gas on the cylinder.

To Start a Run

Select “Run” from the menu and continue as described below.

- Select “Carbon, Hydrogen, Nitrogen Run”. Select “Yes” for a new run
- Check “Enter the Ks and Blanks automatically”. Enter date followed by AM or PM as appropriate for the message of this run series. Select “Enter Data”.
- Sample Entry Screen: Enter Weight (μ g): when entering the weight of the sample press [ENTER] to use the present weight or enter a new weight. If a weight of zero [0] is entered then the ID is assumed to be a blank. If a weight of 100 has been entered the results will be reported in micrograms (μ g). When analyzing aqueous samples, enter the volume filtered (milliliters)/10 as the weight. The results will be reported in μ g /L. When analyzing sediment samples or weighed QC samples, enter the weight in μ g. The result will be reported in %.
- Enter Sample ID: enter the sample ID as either STD1, blank, or any other text. If STD1 is entered as the first three letters, then Ks will be calculated on the result report. If blank is entered, then blanks will be calculated.
- Use the PC/PN bench sheet to set up a wheel. (See Table 5)
- Press “Start Run”

To Insert a Wheel

This mode opens the A, D, F and C valves allowing helium to enter the injection box and minimize air in this area while installing the sample wheel for the 64 sample automatic injector. The pressure will build up and eventually equilibrate to the helium tank pressure if the instrument is left in this mode for a long period of time. This is not recommended; therefore, do not delay carrying out the following steps.

- Open the manual purge valve on the injector box (right side, behind the P valve) to relieve the internal pressure. Loosen the 4 cover screws and lift the lid. Remove the empty wheel from the sample chamber.
- Blow out with canned air any material that might be in the box from previous run.
- Insert the loaded sample wheel with the locking pin in place. Tilt the wheel slightly, line up the scribe mark on the wheel with the ratchet in the housing, lower the wheel and make sure that it is properly seated. Place the locking pin in the center hold. Check that the o-ring of the cover is clean and well seated in the groove.
- Close the cover and tighten equally on all four screws. This should be performed in an alternating sequence to achieve a uniform seal. Never over-tighten or use any tools on the screws.
- Open and remove any spent capsules in the capsule receiver located under the sample chamber. Re-grease the gasket if needed and re-install cover.
- Close the purge valve, let pressure build up for about 30 seconds. Re-open the purge valve for about 5 seconds and then close again.
- Select "OK" to continue operation.

Sample Run

The sample is automatically injected into the combustion tube at the appropriate time. Upon completion of the fill time the ladle is retracted and allowed to cool. At the end of the run the results are printed and the soft key commands are followed if any have been selected.

Once the run begins, the screen displays the following information:

Run number, Sample Weight and ID., the operating K and B values, the preset combustion and purge times, valve status, and the elapsed time in minutes:seconds. Temperatures and Pressure are also displayed near the bottom of the screen. These numbers may not be updated all of the time as time critical sections of a run occur. Run counters for the various tubes are displayed above the valve status diagram. The run counters will change from white to red when they approach 10% within the thresholds set by the user.

During the run the analyst has various options available through the buttons at the top of the screen (accessed via simply selecting one). If a key is actuated, the button changes from grey to white. The buttons are for the following functions:

- **Ks & Bs** - To access the Ks and Bs table at the end of the current run. This allows the operator to change the operating values.
- **PARAMETERS** - Goes to parameters table at the end of the current run.
- **LEAK TEST** - The leak test program is activated at the end of the run cycle.

- **STANDBY** - At the end of the run cycle the instrument will go into standby.
- **DATALOG** - At the end of the run cycle a datalog is printed every half hour. A, D, and F valves are turned on, as in the overnight standby mode.
- **SSI** – A function to activate the single sample inject program after the completion of the current run. The program will automatically resume after the SSI run (unless SSI is pressed again).
- **MENU NEXT** - Goes to the Analytical Menu at the end of the current run. The data will be stored on the data disc at that point.
- **STOP** - Aborts the current operation and goes to the Analytical Menu. This is typically only used during emergency operations. If you exit an HA run cycle prematurely and you wish to start over or resume the HA run with the sample IDs and weights already in memory, then **DO NOT** exit the Analytical Menu. If you exit or reboot the Analytical Menu then the IDs and weights will be erased.
- **NONE** – Nothing at end of run or run cycle.

Tube Replacement

This mode is used when one or more of the reagent tubes in the CE-440 need to be changed, as indicated by the maintenance schedule, poor analytical results or in the case of a cold restart. See instrument manual for additional details on tube replacement beyond this appendix.

Go to the Service Pull-down Menu. Select “Tube Replacement.” “Select CHN Analysis.” Another menu will be displayed that will contain options for tube packing information or for replacement of any tubes used for that analysis. If a new gas cylinder or regulator is to be replaced, select the appropriate item from the menu for changing a tank.

In the individual tube replacement options, follow the step by step instruction shown on the screen. If the procedure is followed correctly and to its conclusion, the Maintenance Schedule Information for that tube will be reset. You can return to the Service Menu at any point by pressing “End.”

Combustion Tube

Hold the tube vertically with the short end from the indentation up. Roll up a piece of platinum gauze so that it will fit snugly into the combustion tube. Slide the gauze plug into the tube and up against the indentation. Add a small plug of quartz wool. (Quartz wool may be muffled for one hour at 850 °C to remove any residual carbon). Add 1½ inches of silver tungstate/magnesium oxide on Chromosorb. Gently tap the tube to prevent the reagent from channeling. Add a small plug of quartz wool. Add 2 inches of silver oxide/silver tungstate on Chromosorb. Tap the tube and add another small plug of quartz wool. Add 2 inches of silver vanadate on Chromosorb. Tap the tube and add another plug of quartz wool. Slide a rolled-up piece of silver gauze into the tube and pack against the quartz wool. Make sure that there is no less than ½ inches of space between the end of the tube and the silver gauze since the silver gauze will conduct heat and damage the o-ring on the end connector. There is rarely such a thing as a “too tightly” packed combustion tube. Loosely packed combustion tubes can cause non-linearity.

- Silver Vanadate on Chromosorb: Reacts with and removes chlorine, bromine, iodine and sulfur contained in the combustion gases. When absorbing sulfur, it changes color from yellow to dark brown when saturated. In absorbing halogens, exhaustion of the silver vanadate is indicated by color changes on the surface of the silver gauze at the end of the combustion tube. Each element forms a distinctively colored salt deposit – silver chloride is gray, silver bromide is brown, and silver iodide is purple.
- Silver Tungstate/Magnesium Oxide on Chromosorb: Removes fluorine, phosphorus, and arsenic.
- Silver Oxide/Silver Tungstate on Chromosorb: Removes sulfur and halogens (except fluorine).
- The silver gauze can be cleaned with water and a small amount of dish soap; swirl for about five minutes, rinse the gauze multiple times with tap water then rinse again with laboratory reagent water. Rinse the gauze with acetone for 30 seconds then dump the waste. Air-dry the gauze thoroughly. Finish by muffling at 550°C for 30 minutes.

Reduction Tube

Pack about ¾ inches of quartz wool into the bottom of the tube from the opposite end. Fill the tube with copper wire while gently tapping to tightly settle the copper and avoid channeling. Pack another plug of quartz wool into the tube against the copper. Insert a rolled-up piece of silver gauze into each small diameter tube end.

Perform a leak test of the combustion-reduction area after tube replacement.

Carbon Dioxide Trap and Gas Scrubbers (2)

These three tubes are identically packed even though the scrubbers are a larger diameter. Pack a ¼ inches plug of quartz wool into one end of the tube. Add 3½ inches Ascarite (Colorcarb) while gently tapping the tube. Add ¼ inches plug of quartz wool. Add 1½ inches magnesium perchlorate while gently tapping the tube. Add ¼ inches plug of quartz wool. There should be about ¼ inches of free space at each end of the tube. Gas scrubbers should be loosely packed to allow for the high gas flows associated with the CE-440. Note the orientation (in the instrument) of the helium and oxygen scrubbers versus the CO₂ trap. The orientation is reversed for the CO₂ trap.

Water Trap

Pack a ¼ inches plug of quartz wool into one end of the tube. Add magnesium perchlorate while gently tapping the tube. Add ¼ inches plug of quartz wool. There should be about ¼ inches of free space at each end of the tube.

Fill time should always be checked after replacing traps and scrubbers. The instrument should be conditioned after replacing maintenance by running two blanks before proceeding to a sample run.

Important Factors for Proper CE-440 Operation

- Oxygen pressure should be at ~ 20 psig.
- Helium pressure should be at ~ 12-18 psig and the fill time for a run should be between 20 and 40 seconds. (This is dependent on regulator type.)
- When greasing o-rings or gaskets, it is recommended to use Krytox (R) by Dupont.
- The furnace temperatures reach set temperature very quickly.
- Never set the combustion temperature above 1100 °C.
- Never set the reduction temperature above 900 °C.